

User Manual

HandyTone-486

Analog Telephone Adaptor

User Manual 1.0 Version



Grandstream Networks, Inc.

www.grandstream.com

Table of Contents

1	WELCOME	3
2	INSTALLATION	4
3	WHAT IS INCLUDED IN THE PACKAGE	5
3.1	SAFETY COMPLIANCES	5
4	PRODUCT OVERVIEW	6
4.1	KEY FEATURES	6
4.2	HARDWARE SPECIFICATION	7
5	BASIC OPERATIONS	8
5.1	GET FAMILIAR WITH KEY PAD AND VOICE PROMPT.....	8
5.2	MAKE PHONE CALLS	9
5.2.1	<i>Calling phone or extension numbers</i>	9
5.2.2	<i>Direct IP calls</i>	9
5.3	CALL FEATURES.....	11
5.3.1	<i>Call Features Table</i>	11
5.3.2	<i>PSTN Pass Through</i>	12
5.4	LED LIGHT PATTERN INDICATION	12
6	CONFIGURATION GUIDE	13
6.1	CONFIGURING HANDYTONE-486 WAN IP THROUGH VOICE PROMPT	13
6.1.1	<i>DHCP Mode</i>	13
6.1.2	<i>STATIC IP Mode</i>	13
6.2	CONFIGURING HANDYTONE-486 WITH WEB BROWSER	13
6.2.1	<i>Access the Web Configuration Menu</i>	13
6.2.2	<i>Configuration Menu</i>	14
6.2.3	<i>Saving the Configuration Changes</i>	24
6.2.4	<i>Rebooting the HandyTone-486 from remotely</i>	24
6.3	CONFIGURATION THROUGH A CENTRAL SERVER	24
7	SOFTWARE UPGRADE	26
7.1	UPGRADE WITH TFTP	26
8	RESTORE FACTORY DEFAULT SETTING	27

1 Welcome

Congratulations on becoming an owner of HandyTone-486. You made an excellent choice and we hope you will enjoy all its capabilities.

Grandstream's award-winning HandyTone-486 is an all-in-one VoIP integrated access device that features superb audio quality, rich functionalities, high level of integration, compactness and ultra-affordability. The HandyTone-486 is fully compatible with SIP industry standard and can interoperate with many other SIP compliant devices and software on the market.

Grandstream HandyTone-486 has been awarded the Best of Show product in 2004 Internet Telephony Conference and Expo.



2 Installation

HandyTone-486 Analog Telephone Adaptor is an all-in-one VoIP integrated device designed to be a total solution for networks providing VoIP services.

The HandyTone-486 VoIP functionalities are available via a regular analog telephone.

The following photo illustrates the appearance of a HandyTone-486.

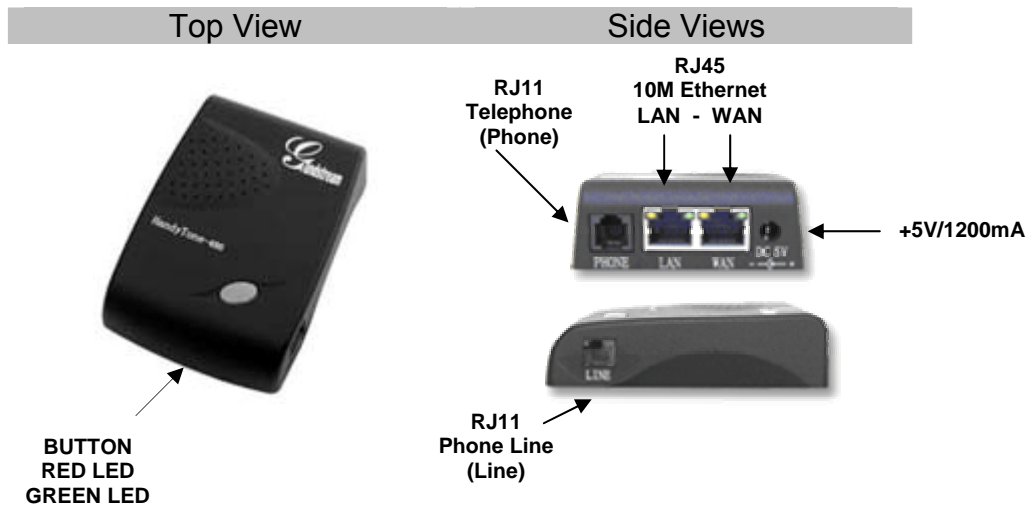

Interconnection Diagram of the HandyTone-486:

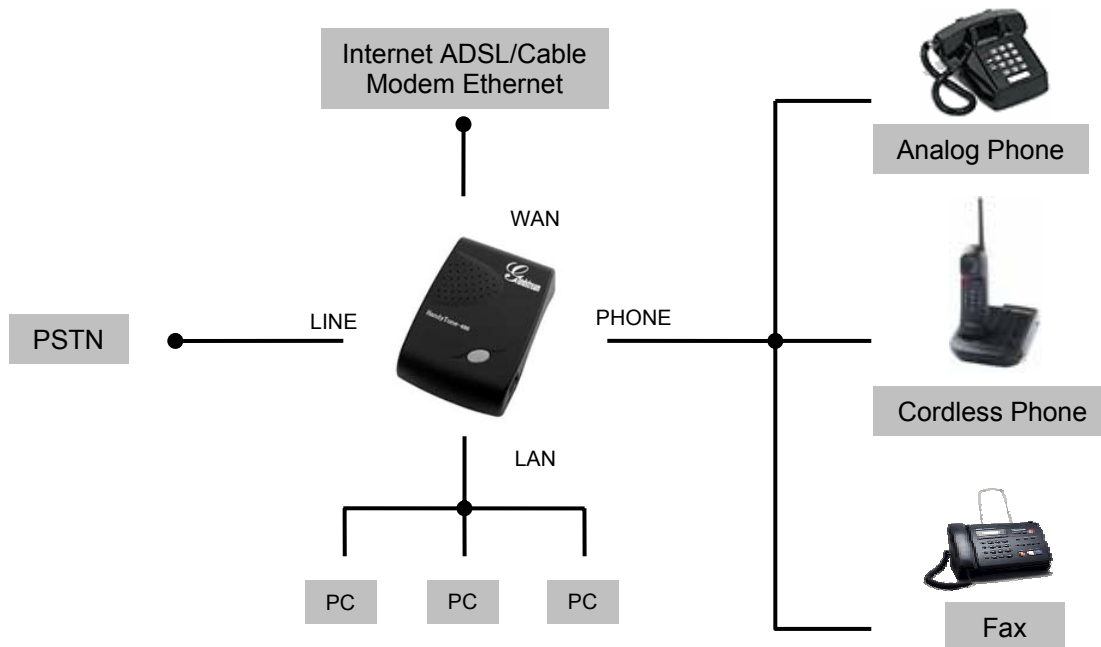

3 What is Included in the Package

The HandyTone-486 package contains:

- 1) One HandyTone-486
- 2) One universal power adaptor
- 3) One Ethernet cable

3.1 Safety Compliances

The HandyTone-486 is compliant with various safety standards including FCC/CE and C-tick. Its power adaptor is compliant with UL standard. The HandyTone-486 should only operate with the universal power adaptor provided in the package.

Warning: Please do not attempt to use a different power adaptor. Using other power adaptor may damage the HandyTone-486 and will void the manufacturer warranty.

Caution: Changes or modifications to this product not expressly approved by Grandstream, or operation of this product in any way other than as detailed by this User Manual, could void your manufacturer warranty.

Information in this document is subject to change without notice. No part of this document may be reproduced or transmitted in any form or by any means, electronic or mechanical, for any purpose without the express written permission of Grandstream Networks, Inc..

4 Product Overview

4.1 Key Features

- Supports SIP 2.0(RFC 3261), TCP/UDP/IP, RTP/RTCP, HTTP, ICMP, ARP/RARP, DNS, DHCP (both client and server), NTP, PPPoE, STUN, TFTP, etc.
- Built-in router, NAT, Gateway and DMZ port forwarding
- Powerful digital signal processing (DSP) to ensure superb audio quality; advanced adaptive jitter control and packet loss concealment technology
- Support various vocoders including G.711 (alaw and u-law), G.723.1 (5.3K/6.3K), G.726 (40K/32K/24K/16K), as well as G.728, G.729A/B, and iLBC.
- Support Caller ID/Name display or block, Hold, Call Waiting/Flash, Call Transfer, Call Forward, in-band and out-of-band DTMF, Dial Plans, etc.
- Support fax pass through
- Support Silence Suppression, VAD (Voice Activity Detection), CNG (Comfort Noise Generation), Line Echo Cancellation (G.168), and AGC (Automatic Gain Control)
- Support standard encryption and authentication (DIGEST using MD5 and MD5-sess)
- Support for Layer 2 (802.1Q VLAN, 802.1p) and Layer 3 QoS (ToS, DiffServ, MPLS)
- Support automated NAT traversal without manual manipulation of firewall/NAT
- Support device configuration via built-in IVR, Web browser or central configuration file through TFTP
- Support firmware upgrade via TFTP
- Ultra compact (wallet size) and lightweight design, great companion for travelers
- Compact, lightweight Universal Power adapter.

4.2 Hardware Specification

The table below describes the difference among these models.

<u>Model</u>	<u>HandyTone-486</u>
LAN interface	1xRJ45 10Base-T
WAN interface	1xRJ45 10Base-T
FXS telephone port	1xFXS
PSTN port	1x life line port
Button	1
LED	Green and red color
Universal Switching Power Adaptor	Input: 100-240VAC 50-60 Hz Output: +5VDC, 1200mA, UL certified
Dimension	70mm (W) 130mm (D) 27mm (H)
Weight	0.6lbs (0.3kg)
Temperature	40 - 130°F 5 – 45°C
Humidity	10% - 90% (non-condensing)
Compliance	

5 Basic Operations

5.1 Get Familiar with Key Pad and Voice Prompt

HandyTone-486 has stored a voice prompt menu for quick browsing and simple configuration.

To enter this voice prompt menu, simply **press the button or “****” from the analog phone.**

Menu	Voice Prompt	User's Options
Main Menu	“Enter a Main Option”	Enter '*' to menu_01 Enter 00-06, 99 menu option
01	“DHCP Mode”, “Static IP Mode”	Enter '9' to toggle the selection
02	“IP Address “ + IP address	It will prompt you with the current WAN IP address. Enter 12 digit new IP address if in Static IP Mode
03	“Subnet “ + IP address	Same as menu 02
04	“Gateway “ + IP address	Same as menu 02
05	“DNS Server “ + IP address	Same as menu 02
06	“TFTP Server “ + IP address	Same as menu 02
47	“Direct IP Calling”	When entered, you will prompt a dialtone, then enter 12 digit IP address This menu can be also entered by pressing the button again
86	“Voice Messages Pending” “No Voice Messages”	Enter 9 to dial pre-configured phone number to retrieve VM
99	“RESET”	Enter '9' to confirm the RESET Enter MAC address to restore factory default setting
	“Invalid Entry”	Automatically return to Main Menu

Notes:

- Once the button is pressed, it enters the voice prompt main menu. If the button is pressed again, while it is already in the voice prompt menu state, it jumps to “*Direct IP Calling*” option and dial tone plays in this state
- '*' functions similar to '↓' key of BT-100 phone to select the next menu option
- '#' returns back to main MENU
- '9' is similar to ENTER key in many cases to confirm an option
- All entered digit sequences have known lengths - 2 digits for menu option and 12 digits for IP address. Once all digits are accumulated, it automatically processes them.
- Key entry cannot be deleted but the phone may prompt error once it is detected

5.2 Make Phone Calls

5.2.1 Calling phone or extension numbers

There are currently two methods to make a extension number call:

- a) Dial the numbers number directly and wait for 4 (default) seconds.
- b) Dial the numbers directly, and press # (assuming that “use #” as dial key is selected in web configuration).

Other functions available during the call are call-waiting/flash, call-transfer, and call-forwarding.

5.2.2 Direct IP calls

Direct IP calling allows 2 phones, that is, a HandyTone with a analog phone and another VoIP Device, to talk to each other in an ad hoc fashion without a SIP proxy. VoIP calls can be made between two phones if:

- both HandyTone ATA and other VoIP Device(i.e., another HandyTone ATA or other HandyTone ATA) have public IP addresses, or
- both HandyTone ATA and other VoIP Device(i.e., another HandyTone ATA or other HandyTone ATA) are on the same LAN using private or public IP addresses, or
- both HandyTone ATA and other VoIP Device(i.e., another HandyTone ATA or other HandyTone ATA) can be connected through a router using public or private IP addresses.

To make a direct IP calling, first pick up the analog phone or turn on the speakerphone on the analog phone, then follow Section 4.1 with voice prompt 47, followed by the 12-digit target IP address. If there is a user part, again follow Section 4.1 with voice prompt 47, and then the encoded user part, followed by *3 (encoding for “@”) and then followed by the 12-digit target IP address. Destination ports can also be specified using *4 (encoding for “:”) followed by the encoded port number.

The follow is a table of the encoding scheme for the most commonly used characters:

F	
00	0
01	1
02	2
03	3
04	4
05	5
06	6
07	7
08	8
09	9
*0	. (dot character)
*1	_ (underscore character)
*2	- (hyphen character)
*3	@
*4	: (column character)
21	A
22	B
23	C
31	D
32	E
33	F
41	G
42	H
43	I
51	J
52	K
53	L
61	M
62	N
63	O
71	P
72	Q
73	R
74	S
81	T
82	U
83	V
91	W
92	X
93	Y
94	Z

The rule of thumb to remember these encoding is: “a” is the first letter on button “1” so its encoding is “11”. “b” is the 2nd letter on button “1” and its encoding is “12”. “c” is the 3rd letter on button “1” and its encoding is “13”. Likewise, “d” is the first letter on button “2” and its encoding is “21”. This pattern and rule applies to all other alphabetic encoding.

Examples:

If the target IP address is 192.168.0.160, the dialing convention is

Voice Prompt with option 47, then 192168000160

followed by pressing the “#” key if it is configured as a send key or wait for more than 5 seconds. In this case, the default destination port 5060 is used if no port is specified.

If the target IP address/port is 192.168.1.20:5062, then the dialing convention would be:

Voice Prompt with option 47, then 192168001020*45062

followed by pressing the “#” key if it is configured as a send key or wait for 5 seconds.

If the target address is john@192.168.1.100:5062, then the dialing convention would be:

Voice Prompt with option 47, then 51634262*3192168001100*45062

followed by pressing the “#” key if it is configured as a send key or wait for 5 seconds.

5.3 Call Features

5.3.1 Call Features Table

Following table shows the call features of HandyTone-486.

Key	Call Features
*70	Do not disturb, it will give caller busy tone when called. This setting will be released when user hangs up the phone.
*72	Unconditional Call Forward. To use this feature, dial “*72” and get the dial tone. Then dial the forward number and hang up.
*73	Cancel Unconditional Call Forward To cancel “Unconditional Call Forward”, dial “*73” and get the dial tone, then hang up.
*90	Busy Call Forward To use this feature, dial “*90” and get the dial tone. Then dial the forward number and hang up.
*91	Cancel Busy Call Forward To cancel “Unconditional Call Forward”, dial “*91” and get the dial tone, then hang up
*92	Delayed Call Forward To use this feature, dial “*92” and get the dial tone. Then dial the forward number and hang up.
*93	Cancel Delayed Call Forward

	To cancel this Forward, dial “*93” and get the dial tone, then hang up
Flash/Hook	When in conversation, this action will switch to the new incoming call if user heard the call waiting sound. When in conversation and no incoming call heard, this action will switch to a new channel for a new call.

5.3.2 PSTN Pass Through

When HandyTone-486 is out of power, the RJ 11 line jack on the HandyTone-486 side will function as a pass through jack, user will be able to use the same analog phone for PSTN calls.

5.4 LED Light Pattern Indication

Following are the LED light pattern indication.

RED LED always indicates not normal status	
DHCP Failed or WAN No Cable	flash every 2 seconds (if DHCP is configured)
HandyTone-486 fails to register	flash every 2 seconds (if SIP server is configured)
GREEN LED always for normal working status	
Message Waiting Indication	Button flashes every 2 seconds
RINGING	Button flashes at 1/10 second
RINGING INTERVAL	Button flashes every second

6 Configuration Guide

6.1 Configuring HandyTone-486 WAN IP through Voice Prompt

6.1.1 DHCP Mode

Follow section 5.1 with voice menu option 01 to enable HandyTone-486 to use DHCP.

6.1.2 STATIC IP Mode

Follow section 5.1 with voice menu option 01 to enable HandyTone-486 to use STATIC IP mode, then use option 02, 03, 04 to set up HandyTone's IP, Subnet Mask, Gateway respectively.

6.2 Configuring HandyTone-486 with Web Browser

HandyTone-486 series ATA has an embedded Web server that will respond to HTTP GET/POST requests. It also has embedded HTML pages that allow a user to configure the HandyTone through a Web browser such as Microsoft's IE and AOL's Netscape.

6.2.1 Access the Web Configuration Menu

The HandyTone-486 HTML configuration menu can be accessed via LAN or WAN port:

- From the LAN port use the default LAN gateway IP address:

http://192.168.2.1

- The WAN port HTML configuration menu option is disabled from factory. To access the HTML configuration menu from the WAN port, first enable the "WAN side HTTP access" option by accessing the configuration via LAN port. With the WAN side HTTP access enable, then get the WAN IP address of the HandyTone through section 4.1 with menu option 02. Then the HandyTone's Web Configuration Menu can be accessed by the following URI via WAN port:

http://HandyTone-IP-Address,

where the ***HandyTone-IP-Address*** is the WAN IP address of the HandyTone-486.

Once this request is entered and sent from a Web browser, the HandyTone-486 will respond with the following login screen:

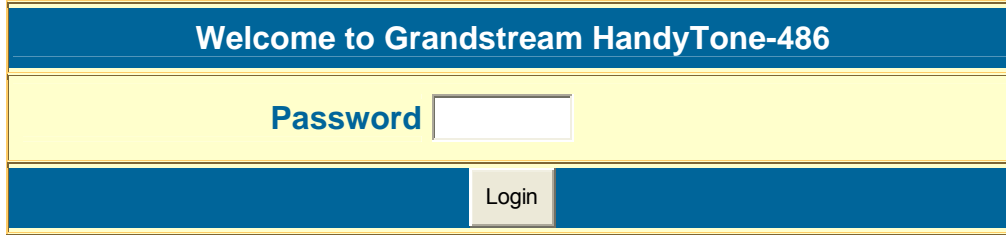

The image shows a login interface for the Grandstream HandyTone-486. It consists of three horizontal sections. The top section is a blue bar with the text "Welcome to Grandstream HandyTone-486" in white. The middle section is a yellow bar with the text "Password" in blue, followed by a white text input field. The bottom section is a blue bar with a grey "Login" button in the center.

The password is case sensitive and the factory default password is lower case '*admin*'.

6.2.2 Configuration Menu

After the correct password is entered in the login screen, the embedded Web server inside the HandyTone-486 will respond with the Configuration Menu screen which is explained in details below.

The definitions for all the configuration parameters in the Configuration Menu are following a sample of the actual configuration page:

Grandstream HandyTone-486 Configuration																														
MAC Address:	00.0B.82.00.XX.XX																													
Product Model:	HT486																													
Software Version:	Program--1.0.X.X Bootloader—1.0.0.XX HTML--1.0.0.XX VOC--1.0.0.5																													
Admin Password:	<input type="password" value="****"/> (password to configure this IP phone)																													
WAN IP Address:	<div style="border: 1px solid black; padding: 5px;"> <input checked="" type="checkbox"/> dynamically assigned via DHCP (default) or PPPoE (will attempt PPPoE if DHCP fails and following is non-blank) <table border="1" style="width: 100%; margin-top: 5px;"> <tr> <td>PPPoE account ID:</td> <td><input type="text"/></td> </tr> <tr> <td>PPPoE password:</td> <td><input type="text"/></td> </tr> </table> <p>Use this DNS server (if specified): <input type="text" value="0"/> . <input type="text" value="0"/> . <input type="text" value="0"/> . <input type="text" value="0"/></p> <input type="checkbox"/> statically configured as: <table border="1" style="width: 100%; margin-top: 5px;"> <tr> <td>IP Address:</td> <td><input type="text" value="192"/></td> <td><input type="text" value="168"/></td> <td><input type="text" value="0"/></td> <td><input type="text" value="160"/></td> </tr> <tr> <td>Subnet Mask:</td> <td><input type="text" value="0"/></td> <td><input type="text" value="0"/></td> <td><input type="text" value="0"/></td> <td><input type="text" value="0"/></td> </tr> <tr> <td>Default Router:</td> <td><input type="text" value="0"/></td> <td><input type="text" value="0"/></td> <td><input type="text" value="0"/></td> <td><input type="text" value="0"/></td> </tr> <tr> <td>DNS Server 1:</td> <td><input type="text" value="0"/></td> <td><input type="text" value="0"/></td> <td><input type="text" value="0"/></td> <td><input type="text" value="0"/></td> </tr> <tr> <td>DNS Server 2:</td> <td><input type="text" value="0"/></td> <td><input type="text" value="0"/></td> <td><input type="text" value="0"/></td> <td><input type="text" value="0"/></td> </tr> </table> </div>	PPPoE account ID:	<input type="text"/>	PPPoE password:	<input type="text"/>	IP Address:	<input type="text" value="192"/>	<input type="text" value="168"/>	<input type="text" value="0"/>	<input type="text" value="160"/>	Subnet Mask:	<input type="text" value="0"/>	<input type="text" value="0"/>	<input type="text" value="0"/>	<input type="text" value="0"/>	Default Router:	<input type="text" value="0"/>	<input type="text" value="0"/>	<input type="text" value="0"/>	<input type="text" value="0"/>	DNS Server 1:	<input type="text" value="0"/>	<input type="text" value="0"/>	<input type="text" value="0"/>	<input type="text" value="0"/>	DNS Server 2:	<input type="text" value="0"/>	<input type="text" value="0"/>	<input type="text" value="0"/>	<input type="text" value="0"/>
PPPoE account ID:	<input type="text"/>																													
PPPoE password:	<input type="text"/>																													
IP Address:	<input type="text" value="192"/>	<input type="text" value="168"/>	<input type="text" value="0"/>	<input type="text" value="160"/>																										
Subnet Mask:	<input type="text" value="0"/>	<input type="text" value="0"/>	<input type="text" value="0"/>	<input type="text" value="0"/>																										
Default Router:	<input type="text" value="0"/>	<input type="text" value="0"/>	<input type="text" value="0"/>	<input type="text" value="0"/>																										
DNS Server 1:	<input type="text" value="0"/>	<input type="text" value="0"/>	<input type="text" value="0"/>	<input type="text" value="0"/>																										
DNS Server 2:	<input type="text" value="0"/>	<input type="text" value="0"/>	<input type="text" value="0"/>	<input type="text" value="0"/>																										
SIP Server:	<input type="text"/> (e.g., sip.mycompany.com, or IP address)																													
Outbound Proxy:	<input type="text"/> (e.g., proxy.myprovider.com, or IP address, if any)																													
SIP User ID:	<input type="text"/> (the user part of an SIP address)																													
Authenticate ID:	<input type="text"/> (can be identical to or different from SIP User ID)																													
Authenticate Password:	<input type="password"/>																													
Name:	<input type="text"/> (optional, e.g., John Doe)																													

Admin Password	This contains the password to access the Web Configuration Menu. This field is case sensitive.
WAN IP Address	<p>There are 2 modes under which the HandyTone ATA can operate:</p> <ul style="list-style-type: none"> - If DHCP mode is enabled, then all the field values for the Static IP mode are not used (even though they are still saved in the Flash memory.) The HandyTone ATA will acquire its IP address from the first DHCP server it discovers from the LAN it is connected to. <p>To use the PPPoE feature set the PPPoE account settings. The Handytone will attempt to establish a PPPoE session if any of the PPPoE fields is set.</p> <ul style="list-style-type: none"> - If Static IP mode is selected, then the IP address, Subnet Mask, Default Router IP address, DNS Server 1 (primary), DNS Server 2 (secondary) fields will need to be configured. These fields are reset to zero by default.
SIP Server	This field contains the URI string or the IP address (and port, if different from 5060) of the SIP proxy server. e.g., the following are some valid examples: sip.my-voip-provider.com, or sip:my-company-sip-server.com, or 192.168.1.200:5066
Outbound Proxy	This field contains the URI string or the IP address (and port, if different from 5060) of the outbound proxy. If there is no outbound proxy, this field SHOULD be left blank. If not blank, all outgoing requests will be sent to this outbound proxy.
SIP User ID	This field contains the user part of the SIP address for this HandyTone ATA. e.g., if the SIP address is: sip:my_user_id@my_provider.com, then the SIP User ID is: my_user_id. Please do NOT include the preceding "sip:" scheme or the host portion of the SIP address in this field.
SIP User ID is Phone Number	If the HandyTone ATA has an assigned PSTN telephone number, then this field will be set to "Yes". Otherwise, set it to "No". If "Yes" is set, a "user=phone" parameter will be attached to the "From" header in SIP request.
SIP Login ID	This field contains the login ID used for SIP authentication. Typically, this is the account number on an SIP server for this HandyTone ATA. It can be the same as or different from the above SIP User ID, depending on whether a separate account ID is used for authentication.
SIP Password	This field contains the password used for SIP authentication. It is used together with the above SIP Login ID

Advanced Options:

Advanced Options:

Preferred Vocoder:
(in listed order)

choice 1:

choice 2:

choice 3:

choice 4:

choice 5:

choice 6:

choice 7:

choice 8:

G723 rate: 6.3kbps encoding rate 5.3kbps encoding rate

iLBC frame size: 20ms 30ms

iLBC payload type: (between 96 and 127, default is 98)

Silence Suppression: No Yes

Voice Frames per TX: (up to 10/20/32/64 for G711/G726/G723/other codecs respectively)

Layer 3 QoS: (Diff-Serv or Precedence value)

Layer 2 QoS: 802.1Q/VLAN Tag 802.1p priority value (0-7)

Use DNS SRV: No Yes

User ID is phone number: No Yes

SIP Registration: Yes No

Unregister On Reboot: Yes No

Register Expiration: (in minutes. default 1 hour, max 45 days)

Early Dial: No Yes (use "Yes" only if proxy supports 484 response)

Dial Plan Prefix: (this prefix string is added to each dialed number)

<i>No Key Entry Timeout:</i>	<input type="text" value="4"/>	(in seconds, default is 4 seconds)
<i>Use # as Dial Key:</i>	<input type="checkbox"/> No <input checked="" type="checkbox"/> Yes	(if set to Yes, "#" will function as the "(Re-)Dial" key)
<i>local SIP port:</i>	<input type="text" value="5060"/>	(default 5060)
<i>Local RTP port:</i>	<input type="text" value="5004"/>	(1024-65535, default 5004)
<i>Use random port:</i>	<input checked="" type="checkbox"/> No <input type="checkbox"/> Yes	
<i>NAT Traversal:</i>	<input checked="" type="checkbox"/> No	
	<input type="checkbox"/> Yes, STUN server is:	<input type="text"/> (URI or IP:port)
<i>keep-alive interval:</i>	<input type="text" value="20"/>	(in seconds, default 20 seconds)
<i>Use NAT IP</i>	<input type="text"/>	(if specified, this IP address is used in SIP/SDP message)
<i>TFTP Server:</i>	<input type="text" value="67"/> . <input type="text" value="153"/> . <input type="text" value="142"/> . <input type="text" value="66"/>	(for remote software upgrade and configuration)
<i>SUBSCRIBE for MWI:</i>	<input checked="" type="checkbox"/> No, do not send SUBSCRIBE for Message Waiting Indication	
	<input type="checkbox"/> Yes, send periodical SUBSCRIBE for Message Waiting Indication	
<i>Offhook Auto-Dial:</i>	<input type="text"/>	(User ID/extension to dial automatically when offhook)
<i>Enable Call Features locally</i>	<input checked="" type="checkbox"/> No <input type="checkbox"/> Yes	(if Yes, Call Forwarding & Do-Not-Disturb are supported locally)
<i>Disable Call-Waiting:</i>	<input checked="" type="checkbox"/> No <input type="checkbox"/> Yes	
<i>Send DTMF:</i>	<input checked="" type="checkbox"/> in-audio <input type="checkbox"/> via RTP (RFC2833) <input type="checkbox"/> via SIP INFO	
<i>DTMF Payload Type:</i>	<input type="text" value="101"/>	
<i>Send Flash Event:</i>	<input checked="" type="checkbox"/> No <input type="checkbox"/> Yes	(Flash will be sent as a DTMF event if set to Yes)
<i>FXS Impedance:</i>	<input type="text"/>	
<i>NTP Server:</i>	<input type="text" value="time.nist.gov"/>	(URI or IP address)
<i>Time Zone:</i>	<input type="text"/>	
<i>Daylight Savings Time:</i>	<input checked="" type="checkbox"/> No <input type="checkbox"/> Yes	(if set to Yes, display time will be 1 hour ahead of normal time)
<i>Send Anonymous:</i>	<input checked="" type="checkbox"/> No <input type="checkbox"/> Yes	(caller ID will be blocked if set to Yes)
<i>Lock keypad update:</i>	<input checked="" type="checkbox"/> No <input type="checkbox"/> Yes	(configuration update via keypad is disabled if set to Yes)
<i>WAN side http access:</i>	<input checked="" type="checkbox"/> No <input type="checkbox"/> Yes	(WAN side access to http server will be rejected if set to No)

Preferred Vocoder	<p>The BudgeTone HandyTone ATA supports up to 6 different vocoder types including G.711 A-/U-law, G.723.1, G.726, G.728, G.729A/B, iLBC. Depending on the product model, some of these vocoders may not be provided in standard release.</p> <p>A user can configure vocoders in a preference list that will be included with the same preference order in SDP message. The first vocoder in this list can be entered by choosing the appropriate option in “Choice 1”. Similarly, the last vocoder in this list can be entered by choosing the appropriate option in “Choice 6”.</p>
G723 Rate:	This defines the encoding rate for G723 vocoder. By default, 6.3kbps rate is chose.
iLBC frame size:	This sets the iLBC size in 20ms or 30ms
iLBC payload type:	This defines payload time for iLBC. Default value is 98. The valid range is between 96 and 127.
Silence Suppression	This controls the silence suppression/VAD feature of G723 and G729. If set to “Yes”, when a silence is detected, small quantity of VAD packets (instead of audio packets) will be sent during the period of no talking. If set to “No”, this feature is disabled.
Voice Frames per TX	<p>This field contains the number of voice frames to be transmitted in a single packet. When setting this value, the user should be aware of the requested packet time (used in SDP message) as a result of configuring this parameter. This parameter is associated with the first vocoder in the above vocoder Preference List or the actual used payload type negotiated between the 2 conversation parties at run time.</p> <p>e.g., if the first vocoder is configured as G723 and the “Voice Frames per TX” is set to be 2, then the “ptime” value in the SDP message of an INVITE request will be 60ms because each G723 voice frame contains 30ms of audio. Similarly, if this field is set to be 2 and if the first vocoder chosen is G729 or G711 or G726, then the “ptime” value in the SDP message of an INVITE request will be 20ms.</p> <p>If the configured voice frames per TX exceeds the maximum allowed value, the HandyTone ATA will use and save the maximum allowed value for the corresponding first vocoder choice. The maximum value for PCM is 10(x10ms) frames; for G726, it is 20 (x10ms) frames; for G723, it is 32 (x30ms) frames; for G729/G728, 64 (x10ms) and 64 (x2.5ms) frames respectively.</p>
Layer 3 QoS	This field defines the layer 3 QoS parameter which can be the value used for IP Precedence or Diff-Serv or MPLS. Default value is 48.
Layer 2 QoS	This contains the value used for layer 2 VLAN tag. Default setting is blank.

Use DNS SRV:	Default is No. If set to Yes the
User ID is Phone Number	If the HandyTone ATA has an assigned PSTN telephone number, then this field will be set to “Yes”. Otherwise, set it to “No”. If “Yes” is set, a “user=phone” parameter will be attached to the “From” header in SIP request
SIP Registration	This parameter controls whether the HandyTone ATA needs to send REGISTER messages to the proxy server. The default setting is “Yes”.
Unregister on Reboot	Default is No. If set to yes, the SIP user will be unregistered on reboot.
Register Expiration	This parameter allows the user to specify the time frequency (in minutes) the HandyTone ATA will refresh its registration with the specified registrar. The default interval is 60 minutes (or 1 hour). The maximum interval is 65535 minutes (about 45 days).
Early Dial	Default is No. Use only if proxy supports 484 response
Dial Plan Prefix	Sets the prefix added to each dialed number
No Key Entry timeout	Default is 4 seconds.
Use # as Send Key	This parameter allows the user to configure the “#” key to be used as the “Send”(or “Dial”) key. Once set to “Yes”, pressing this key will immediately trigger the sending of dialed string collected so far. In this case, this key is essentially equivalent to the “(Re)Dial” key. If set to “No”, this # key will then be included as part of the dial string to be sent out.
Local SIP port	This parameter defines the local SIP port the HandyTone ATA will listen and transmit on. The default value is 5060.
Local RTP port	This parameter defines the local RTP-RTCP port pair the HandyTone ATA will listen and transmit on. It is the base RTP port for channel 0. When configured, channel 0 will use this port_value for RTP and the port_value+1 for its RTCP; channel 1 will use port_value+2 for RTP and port_value+3 for its RTCP. The default value is 5004.
Use Random Port	This parameter, when set to Yes, will force random generation of both the local SIP and RTP ports. This is usually necessary when multiple HandyTone ATAs are behind the same NAT.

NAT Traversal	<p>This parameter defines whether the HandyTone ATA NAT traversal mechanism will be activated or not. If activated (by choosing “Yes”) and a STUN server is also specified, then the HandyTone ATA will behave according to the STUN client specification. Under this mode, the embedded STUN client inside the HandyTone ATA will attempt to detect if and what type of firewall/NAT it is behind through communication with the specified STUN server. If the detected NAT is a Full Cone, Restricted Cone, or a Port-Restricted Cone, the HandyTone ATA will attempt to use its mapped public IP address and port in all the SIP and SDP messages it sends out.</p> <p>If this field is set to “Yes” with no specified STUN server, then the HandyTone ATA will periodically (every 10 seconds or so) send a blank UDP packet (with no payload data) to the SIP server to keep the “hole” on the NAT open.</p>
Use NAT IP:	NAT IP address used in SIP/SDP message. Default is blank.
TFTP Server	<p>This is the IP address of the configured tftp server. If it is non-zero or not blank, the HandyTone ATA will attempt to retrieve new configuration file or new code image from the specified tftp server at boot time. It will make up to 3 attempts before timeout and then it will start the boot process using the existing code image in the Flash memory. If a tftp server is configured and a new code image is retrieved, the new downloaded image will be verified and then saved into the Flash memory.</p>
Subscribe for MWI:	Default is NO. When set to Yes a SUBSCRIBE for Message Waiting Indication will be sent periodically.
Offhook Auto-Dial	<p>This parameter allows the user to configure a User ID or extension number to be automatically dialed upon offhook. Please note that only the user part of a SIP address needs to be entered here. The HandyTone ATA will automatically append the “@” and the host portion of the corresponding SIP address.</p>
Enable Call Features	Default is No. If set to Yes, Call Forwarding & Do-Not-Disturb are supported locally
Disable Call Waiting	Default is Not.
Send DTMF	<p>This parameter controls the way DTMF events are transmitted. There are 3 ways: in audio which means DTMF is combined in audio signal (not very reliable with low-bit-rate codec), via RTP (RFC2833), or via SIP INFO.</p>
DTMF Payload Type	.

<i>Send Flash Event</i>	This parameter allows the user to control whether to send an SIP NOTIFY message indicating the Flash event, or just to switch to the voice channel when the user presses the Flash key.
<i>FXS Impedance</i>	Selects the impedance of the analog telephone connected to the Phone port.
<i>NTP server</i>	This parameter defines the URI or IP address of the NTP server which the HandyTone ATA will use to display the current date/time.
<i>Time Zone</i>	This parameter controls how the displayed date/time will be adjusted according to the specified time zone.
<i>Daylight Savings Time</i>	This parameter controls whether the displayed time will be daylight savings time or not. If set to Yes, then the displayed time will be 1 hour ahead of normal time.
<i>Send Anonymous</i>	If this parameter is set to “Yes”, the “From” header in outgoing INVITE message will be set to anonymous, essentially blocking the Caller ID from displaying.
<i>Lock keypad update</i>	If this parameter is set to “Yes”, the configuration update via keypad is disable.
<i>WAN side http access</i>	If this parameter is set to “No”, the HTML configuration update via WAN port is disable.

NAT/DHCP Server Configuration:

NAT/DHCP Server Information & Configuration:

WAN IP Address:	192.168.XX.XX							
Cloned WAN MAC Addr:	<input type="text"/>	<input type="text"/>	<input type="text"/>	<input type="text"/>	<input type="text"/>	<input type="text"/>	(in hex format)	
LAN Subnet Mask:	<input type="text"/>						(default is 255.255.255.0)	
LAN DHCP Base IP:	<input type="text"/>						(base IP for the LAN port, default is 192.168.2.1)	
DHCP IP Lease Time:	<input type="text" value="0"/>						(in units of hours, default is 120 hours or 5 days)	
DMZ IP:	<input type="text"/>							
Port Forwarding:	WAN port	<input type="text" value="0"/>	LAN IP	<input type="text"/>	LAN port	<input type="text" value="0"/>	Protocol	"UDP Only" ▼
	WAN port	<input type="text" value="0"/>	LAN IP	<input type="text"/>	LAN port	<input type="text" value="0"/>	Protocol	"UDP Only" ▼
	WAN port	<input type="text" value="0"/>	LAN IP	<input type="text"/>	LAN port	<input type="text" value="0"/>	Protocol	"UDP Only" ▼
	WAN port	<input type="text" value="0"/>	LAN IP	<input type="text"/>	LAN port	<input type="text" value="0"/>	Protocol	"UDP Only" ▼
	WAN port	<input type="text" value="0"/>	LAN IP	<input type="text"/>	LAN port	<input type="text" value="0"/>	Protocol	"UDP Only" ▼
	WAN port	<input type="text" value="0"/>	LAN IP	<input type="text"/>	LAN port	<input type="text" value="0"/>	Protocol	"UDP Only" ▼
	WAN port	<input type="text" value="0"/>	LAN IP	<input type="text"/>	LAN port	<input type="text" value="0"/>	Protocol	"UDP Only" ▼
	WAN port	<input type="text" value="0"/>	LAN IP	<input type="text"/>	LAN port	<input type="text" value="0"/>	Protocol	"UDP Only" ▼

WAN IP Address	Shows the IP address at the WAN side of the HandyTone-486.
Cloned WAN MAC Address:	Allow the user to set a specific MAC address. Set in Hex format
LAN Subnet Mask	Sets the LAN subnet mask. Default value is 255.255.255.0
LAN DHCP Base IP:	Base IP for the LAN port, which function as a Gateway for the subnet. Default value is 192.168.2.1
DHCP IP Lease Time:	Value is set in units of hours. Default value is 120hr (5 Days.) The time IP address are assigned to the LAN clients
DMZ IP:	Forward all WAN IP traffic to a specific IP address if no matching port is used by HandyTone-486 itself or in the defined port forwarding.
Port Forwarding:	Allow the user to forward a matching (TCP/UDP) port to a specific LAN IP address with a specific (TCP/UDP) port.

6.2.3 Saving the Configuration Changes

Once a change is made, the user should press the “Update” button in the Configuration Menu. The HandyTone ATA will then display the following screen to confirm that the changes have been saved.

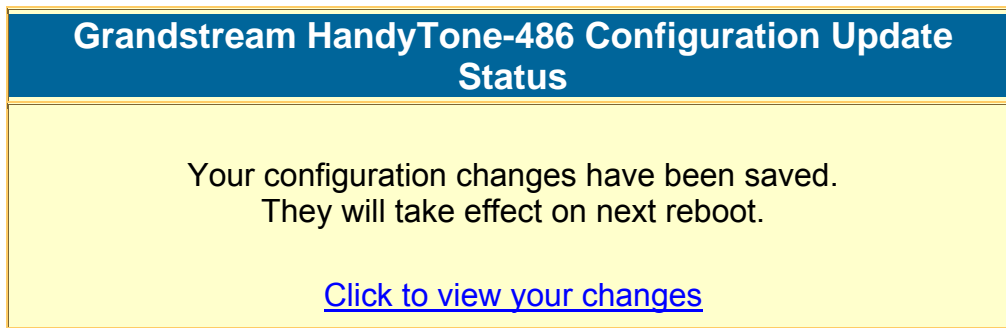

The user is recommended to power cycle the HandyTone-486 after seeing the above message.

6.2.4 Rebooting the HandyTone-486 from remotely

The administrator of the HandyTone-486 can remotely reboot the HandyTone ATA by pressing the “Reboot” button at the bottom of the configuration menu. Once done, the following screen will be displayed to indicate that rebooting is underway.

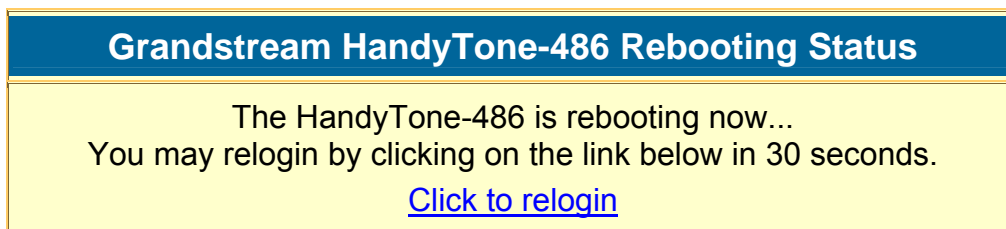

At this point, the user can relogin to the HandyTone ATA after waiting for about 30 seconds.

6.3 Configuration through a Central Server

Grandstream HandyTone ATAs can be automatically configured from a central provisioning system.

The configuration file is downloaded via TFTP from the central server. A service provider or an enterprise with large deployment of HandyTone ATAs can easily manage the configuration and service provisioning of individual devices remotely and automatically from a

central server. GAPS uses enhanced (NAT friendly) TFTP and other communication protocols to communicate with each individual HandyTone ATA even if the HandyTone ATA is behind a NAT.

Grandstream provide licensed provisioning system(GAPS series, stand for Grandstream Automated Provisioning System) that can be used to support automated configuration of HandyTone ATA. To enable this feature on the HandyTone ATA, the user just needs to enter the IP address of the GAPS server in the TFTP server field of the configuration screen. Then reboot the HandyTone ATA.

For details on how GAPS works, please refer to the documentation of GAPS product.

7 Software Upgrade

7.1 Upgrade with TFTP

To upgrade software, HandyTone ATAs can be configured with a TFTP server where the new code image is located. The TFTP upgrade can work in either static IP or DHCP mode using private or public IP address. It is recommended that the TFTP server must have either public IP address or be on the same LAN with the HandyTone ATA.

There are 2 ways to set up the TFTP server to upgrade the firmware, namely through voice menu prompt or via the HandyTone ATA's Web configuration interface. To configure the TFTP server via voice prompt, follow section 4.1 with option 06, once set up the tftp ip address, power cycle the ATA, the firmware will be fetched once the ATA boot up.

To configure the TFTP server via the Web configuration interface, open up your browser to point at the IP address of the HandyTone ATA. Input the admin password to enter the configuration screen. From there, enter the TFTP server address in the designated field towards the bottom of the configuration screen.

Once the TFTP server is configured, power cycle the HandyTone ATA.

TFTP checking is only performed during the initial power up. If the configured tftp server is found and a new code image is available, the HandyTone ATA will attempt to retrieve the new image files by downloading them into the HandyTone ATA's SRAM. During this stage, the HandyTone ATA's LEDs will blink until the checking/downloading process is completed. Upon verification of checksum, the new code image will then be saved into the Flash. If TFTP fails for any reason (e.g., TFTP server is not responding, there are no code image files available for upgrade, or checksum test fails, etc), the HandyTone ATA will stop the TFTP process and simply boot using the existing code image in the flash.

TFTP may take as long as 1—2 minutes over Internet, or just 20+ seconds if it is performed on a LAN. It is generally recommended to conduct TFTP upgrade in a controlled LAN environment if possible. For users who do not have local TFTP server, Grandstream provides a NAT-friendly TFTP server on the public Internet for users to download the latest firmware upgrade automatically. Please check the Service or Support section of Grandstream's Web site to obtain this TFTP server IP address.

8 Restore Factory Default Setting

Warning: Restore the Factory Default Setting will delete all configuration information of the device.

Step one: Find the Mac Address of the device. The Mac address of the device is located on the bottom of the device. It is a 12 digits number.

Step two: Encode the Mac address. The encode rule is:

“2” is the first letter on the button “2” so its encoding is “2”.

“A” is the second letter on button “2” so its encoding is “22”.

“B” is the third letter on button “2” and its encoding is “222”.

“C” is the fourth letter on button “2” and its encoding is “2222”.

For example, the Mac address is 000b8200e395,

User should encode it as “00022228200333395”.

Step three: Access the voice menu, then dial “99” and get the voice prompt “RESET”

Step four: Dial in the encode of the Mac address. Once the correct encode Mac address dial in, the device will reboot automatically and restore the factory default setting.